

ULTRALow maxx

By Motion Concepts

Maximum Control. Maximum Comfort.



Trusted Solutions, Passionate People



A new benchmark for complex rehab power positioning

The **Ultra Low Maxx** is a powered positioning system designed to provide **the most individualized fit** possible, bringing **increased function and independence** to client's daily lives.

We have called the system '**Maxx**' because it is a real-world solution providing **maximum control** and **maximum comfort**.

Already an **established leader** in the North American **complex rehab market**, the Ultra Low Maxx is now bringing its **unparalleled levels of adjustability, comfort and support** to Europe.

With up to 50° of Centre of Gravity (CoG) tilt and 170° recline with **class leading Extended Shear Reduction (ESR) technology** which, along with its extensive number of seating options, is the **perfect solution to enhance mobility**.

Shear reduction

Extended Shear Reduction technology

One of the core technologies in the Ultra Low Maxx is a **170° recline module**, which has been designed to **work with the body's natural pivot points**.

Extended Shear Reduction (ESR) technology allows a client to sit 'in' the system rather than 'on top' of it, with the back rest adjusting up to 115mm during the full 170° recline cycle.

This function, combined with a raised pivot point and the specially integrated backrest, **ensures the client does not**

slide down the chair, instead remaining **stably positioned** throughout the entire recline cycle.

In addition, accessories such as headrests, trunk supports, user controls and head arrays have all been **built to provide the same, consistent level of support throughout the entire range of movement** - essential for clients who are unable to reposition themselves and those at high risk of skin tissue breakdown.



**Power recline with the ultimate
in shear reduction technology**

Maximum levels of pressure
distribution and support



Multiple positions to reduce pressure ulcer risk

The Ultra Low Maxx offers up to **50° of posterior tilt and 170° of recline**, allowing clients a wide variety of positioning combinations. Varying the degrees of combined tilt and recline allows clients to **find their own individual position** for pressure redistribution, function and comfort. By combining greater degrees of tilt and recline, clients can **reduce interface pressure in areas more prone to pressure ulcers by more than double** when compared to traditional seating systems.

Even with a significant 50° of tilt, the **stability of the power wheelchair and the safety of the individual is assured** due to the tilt mechanism's integrated Centre of Gravity (CoG) movement and built-in electronic inhibit function. Also, for those individuals with unique weight distribution, the centre of gravity of the entire seat - relative to the base - can be easily adjusted to ensure **optimal drive performance at all times**.

Manage lower extremity oedema and prevent contractures

The LNX power centre mount foot platform **provides a superior level of support** to a client's legs and calves **throughout the entire range of movement**.

For clients with lower extremity oedema, the LNX power centre mount foot platform can be used in conjunction with the Ultra Low Maxx's greater degrees of tilt and recline **to allow the positioning of legs above heart level**, facilitating the **reduction of swelling**. In addition, the powered leg rest adjustment can be used to help **stimulate the range of movement** in a client's knee, helping to **prevent contractures due to inactivity**.





**Allowing clients to reach further
and more fully interact with their
environment**

Seat lift

Anterior assist and seat lift

The Ultra Low Maxx has two key features that can greatly enhance a client's day-to-day functions; **anterior assist** and **seat lift**.

Available in both 5° and 10° options, the **anterior assist feature** helps clients to perform transfers by lowering their knees in relation to their hips to assist getting in and out of the chair. This can also promote trunk extension, **allowing clients to reach further and more fully interact with their environment**.

The **seat lift feature** allows the seat to be raised up to 300mm, allowing clients to **naturally participate in eye-level communication** reducing any neck and shoulder strain. In addition, these features **assist with simple daily tasks** like transfers, reaching objects on shelves, and even just enjoying time with friends.



Little things make a big difference

A modular frame with an intimate fit

The Ultra Low Maxx is a **highly modular and adjustable system** designed to adapt over time as needs change. From a younger, growing client to an adult with fluctuating weight, **the seating system has a wide array of integrated adjustments.**

Two width packages are available - 405-505mm and 505-610mm - each can be **adjusted in increments of 25mm.** These are interfaced with two depth packages - 380-480mm and 480-580mm - which can be finitely adjusted **by simply loosening four bolts and sliding the rail forward.**

The Ultra Rail is a modular slotted rail designed to allow the easy mounting of positioning accessories like pelvic belts and hip supports. The 'Maxx Style' lateral hip supports are available with three different pad sizes and are **highly adjustable to allow a more intimate fit, ensuring support exactly where it is needed.**

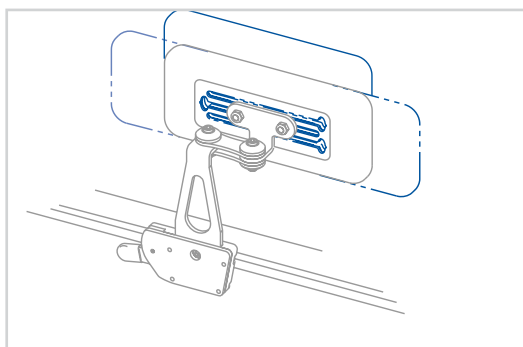

Width & Depth	Small Width Package	Large Width Package	Short Depth Package	Long Depth Package
Adjustment Ranges	405 to 505 mm in 25 mm steps	505 to 610 mm in 25 mm steps	380 to 480 mm finite	480 to 580 mm finite

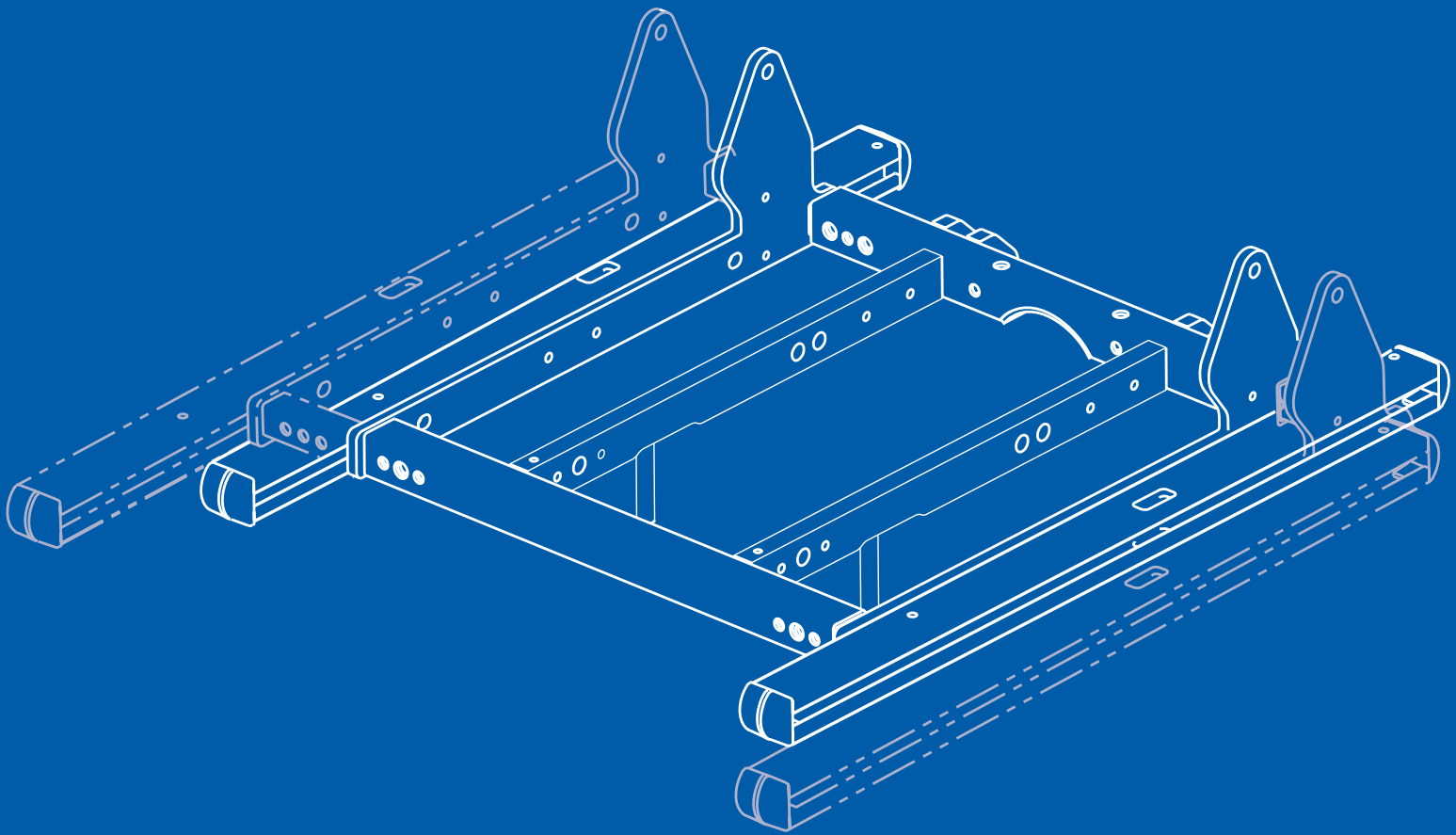
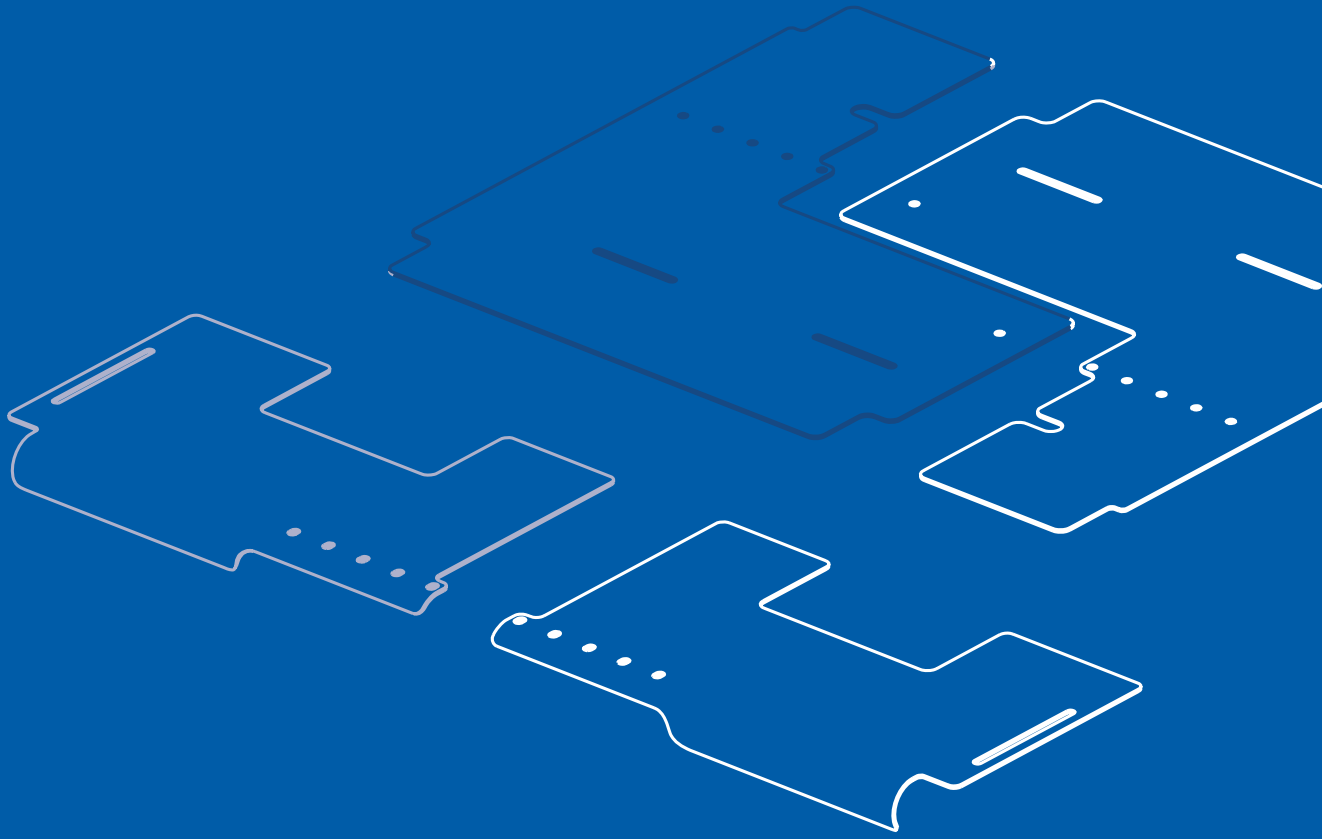

Back supports

Multiple levels of trunk control

There are four unique backrests available with the Ultra Low Maxx. In addition to our standard High Back there are 3 models available on-chair from our highly regarded seating line- the Matrx Elite TR, Matrx PB, and Matrx Elite Deep. All of these backrests are designed to seamlessly mount on the Ultra Track - a sleek, one-piece, gliding aluminum extrusion that works in harmony with the ESR mechanism.

Each backrest is an integrated part of the ESR mechanism ensuring there is **no loss of seat depth**, with the natural pivot point of hip joints residing closer to the recline mechanism, this keeps the ESR mechanism **working with the same efficiency** regardless of the back chosen. Furthermore if the client's postural support needs change, an alternative back can be used **without any compromise on comfort or positioning.**

Clients with trunk asymmetries - and who require further support - will benefit from the use of the highly adjustable, Maxx Style swing-away lateral supports, which are mounted on the **Ultra Track.**





Matrx Elite deep



Matrx PB back



Matrx Elite TR



There are four unique backrest models available on the Ultra Low Maxx



Maximum support for legs

Supporting the feet and calves throughout the movement.

The Ultra Low Maxx offers both the **LNX power centre mount foot platform** and swing-away **Pivot Plus Dual Mount legrests** to provide maximum support for the feet and calves.

The new LNX centre mount legrests benefit clients with legs in adduction due to high tone, **offering a more efficient midline support**. In addition, a centre mount platform can greatly **reduce the overall footprint** of the power base, **reducing the turning radius**.

New LNX power centre mount features:

- A unique two bar linkage calf pad to ensure **excellent support throughout movement**
- Articulation in elevation
- Footplates which have **individually adjustable height, angle and widths**
- The **availability of +/- 7 degree starting angles adjustments**

Power or manual elevating Pivot Plus legrests

The Pivot Plus Dual Mount elevating legrests **offer a rigid, solid structure** essential for clients with high tone who put a lot of stress on front riggings. **Designed for those that require independent elevation of each leg**, these legrests have rollers placed in the footplates and legrest tubes to provide **an additional level of mobility** for navigating every day obstacles.





Modular arm pads allow for wide range of positioning options

Upper Extremity support

Maximum positioning and support of the arms

Support of the upper extremities is crucial to **ensure improved trunk stability**, to **increase comfort**, and to **reduce strain on the shoulder girdle**. Correct support can reduce pressure on the weight bearing bones of the pelvis **by up to 30%**. In light of this, the Ultra Low Maxx offers two different style armrest options:

- **'Cantilever style' armrests** which are width adjustable and easily flip back for transfers, whilst still keeping the ultra rail available for use with positioning supports
- **Traditional 'two post' recline armrests**, offer additional support to maintain a high level of durability for transfers

Both styles are designed to follow the full recline throughout the movement, **ensuring continuous upper extremity support**.

The ergonomic arm trough can be used on its own for support or in combination with the flat hand pad for additional support. For those unable to maintain a neutral arm position, the **Multi Axis Armrest Mount (MACES)** can be added to better position the pad, providing the correct level of support, **accommodating limitations in shoulder range of motion** and providing a stable level of access to controls being used.



Your choice for complex rehab power positioning

The **Invacare TDX2 Ultra** brings a new, class leading, high performance centre wheel drive power wheelchair to the market.

Working together to **set a new benchmark for the complex rehab power positioning arena**, the TDX2 Ultra will revolutionize the way a client sits with its **outstanding manoeuvrability, exceptional functionality** and includes an **extensive range of integrated Matrix seating options**.

Speak with your Invacare representative today to find out more about features like:

- **Class leading, shear reduction** with the ESR Mechanism
- **Simple and precise adjustability** features leading to a perfect fit
- **Advanced tilt and recline features** to maximise comfort and pressure relief
- **Excellent drive performance** with Stability Lock and SureStep® Technology

